

# SPINOZASOL®

## LFP 16kWh/LV

**51.2V 314Ah**

Rechargeable lithium battery

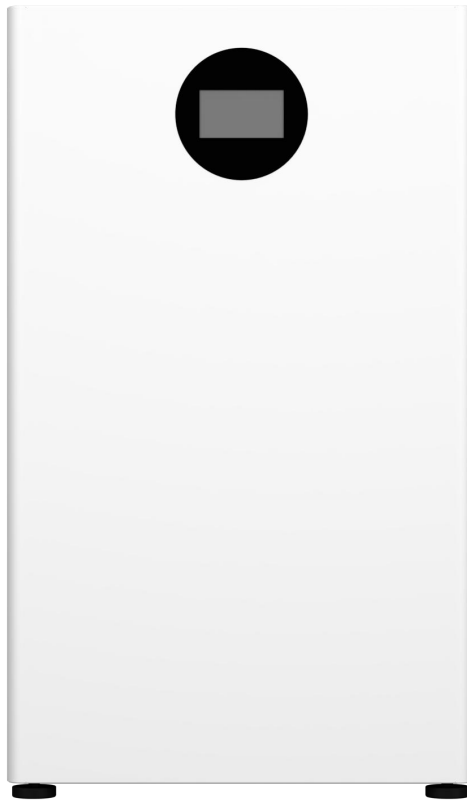

**User Manual**

V3.0

**spinozasol.cl**

## COTNETS

Statement of Law .....	3
Revision History .....	3
Safety Precautions .....	4
Preface .....	6
1 Introduction .....	8
1.1 Brief Introduction .....	8
1.2 Product Properties .....	8
1.3 Product identity definition .....	9
2 Product specifications .....	10
2.1 System Performance Parameter .....	10
2.2 Interface Definition .....	11
2.3 Battery Management System(BMS) .....	12
3 Installation and Configuration .....	14
3.1 Preparations for Installation .....	14
3.2 Equipment installation .....	18
4 Use, Maintenance and Troubleshooting .....	22
4.1 Battery System Usage and Operation Instructions .....	22
4.2 Display screen operation Instructions .....	23
4.3 Alarm Description and Processing .....	24
4.4 Analysis and Treatment of Common Faults .....	25
5 Bluetooth Application Connection Guide .....	27
5.1 Android and iOS Software download and Installation .....	27
5.2 User Login .....	27
5.3 Device Connection .....	28
5.4 APP Main Interface Display .....	28
5.5 Other interface displays .....	31

## Statement of Law

The copyright of this document belongs to us.

Without our prior written permission, no part of this document may be excerpted, copied, translated, annotated, or reused in any form or by any means. All rights reserved.

This product complies with environmental protection design requirements and personal safety standards. The storage, use, and disposal of the product shall be carried out in accordance with the product manual, relevant contracts, or relevant laws and regulations.

Customers can inquire about relevant information through the website when the product technology is updated.

Please note that this product may be modified without prior notice.

**Manual Version: V2.0**

**Manual NO.**

## Revision History

Revision NO.	Revision Date	Revision Reason
V1.0	2024.12.12	First Published
V1.1	2025.11.28	Add Refine and improve installation details
V2.0	2025.12.05	Update product version data
V3.0	2026.4.22	Expanding to a 16-cell battery pack

## Safety Precautions **Précautions de sécurité**

### **Warning Avertissement**

- Please do not put the battery into water or fire, in case of explosion or any other situation that might endanger your life.
- Please connect wires properly while installation, do not reverse connect.
- To avoid short circuit, please do not connect positive and negative poles with conductor (Wires for instance).
- Please do not stab, hit, trample or strike the battery in any other way.
- Please shut off the power completely when removing the device or reconnecting wires during the daily use or it could cause the danger of electric shock.
- Please use dry powder extinguisher to put out the flame when encountering a fire hazard, liquid extinguisher could result in the risk of secondary disaster.
- For your safety, please do not arbitrarily dismantle any component in any circumstances unless a specialist or an authorized one from our company, device breakdown due to improper operation will not be covered under warranty.
- Ne pas mettre la batterie dans l'eau ni au feu, afin d'éviter toute explosion ou toute autre situation susceptible de mettre votre vie en danger.
- Veuillez connecter correctement les fils lors de l'installation; ne pas inverser les connexions.
- Pour éviter tout court-circuit, ne pas connecter les pôles positif et négatif à un conducteur (par exemple, des fils).
- Veuillez éviter de percer, de frapper, de piétiner ou de heurter la batterie de quelque manière que ce soit.
- Veuillez couper complètement l'alimentation lorsque vous retirez l'appareil ou rebranchez les fils pendant l'utilisation quotidienne, car cela pourrait provoquer un risque d'électrocution.
- Veuillez utiliser un extincteur à poudre sèche pour éteindre les flammes en cas de risque d'incendie; un extincteur liquide pourrait entraîner un risque de catastrophe secondaire.
- Pour votre sécurité, ne démontez aucun composant de manière arbitraire, sauf par un spécialiste ou un technicien agréé par notre entreprise. Toute panne due à une mauvaise utilisation de l'appareil ne sera pas couverte par la garantie.

### **Caution Attention**

- We have strict inspection to ensure the quality when products are shipped out, however, please contact us if case bulging or another abnormal phenomenon.
- For your safety, device shall be ground connected properly before normal use.
- To assure the proper use please make sure parameters among the relevant device are compatible.

- Please do not mixed-use batteries from different manufacturers, different types and models, as well as old and new together.
- Ambient and storage method could impact the life span and product reliability, please consider the operation environment abundantly to make sure device works in proper condition.
- For long-term storage, the battery should be recharged once every 6 months, and the amount of electric charge shall exceed 80% of the rated capacity.
- Please charge the battery in 18 hours after it discharges fully and starts over-discharging protection.
- Formula of theoretical standby time:  $T=C/I$  (T is standby time, C is battery capacity, I is total current of all loads).
- Nous effectuons des contrôles rigoureux pour garantir la qualité de nos produits à l'expédition. Veuillez toutefois nous contacter en cas de gonflement ou de tout autre phénomène anormal.
- Pour votre sécurité, l'appareil doit être mis à la terre et correctement connecté avant toute utilisation normale.
- Pour garantir une utilisation optimale, veuillez vous assurer que les paramètres des appareils concernés sont compatibles.
- Veuillez ne pas utiliser de piles de fabricants, de types et de modèles différents, ni de piles neuves et anciennes.
- Les conditions ambiantes et les méthodes de stockage peuvent avoir un impact sur la durée de vie et la fiabilité du produit. Veuillez tenir compte de l'environnement d'utilisation pour vous assurer du bon fonctionnement de l'appareil.
- Pour un stockage longue durée, la batterie doit être rechargée tous les 6 mois et la charge électrique doit dépasser 80 % de sa capacité nominale.
- Veuillez charger la batterie pendant 18 heures après qu'elle soit complètement déchargée et que la protection contre la décharge excessive soit activée.
- Formule de l'autonomie théorique en veille:  $T = C/I$  (T = autonomie en veille, C = capacité de la batterie, I = courant total de toutes les charges).

## Preface

### Manual Declaration

LFP 16kWh Low Voltage User Manual lithium iron phosphate battery is an external battery module that can store electrical energy for households. When the power grid is energized, the device supplies power to household loads while charging the battery; when the power grid is cut off, the battery supplies power to household loads through discharge.

The "LFP 16kWh Low Voltage User Manual" systematically elaborates on the device structure, parameters, basic installation procedures and methods, as well as key points of operation and maintenance.

### Déclaration du manuel

**Manuel d'utilisation de la batterie lithium fer phosphate LFP 16 kWh/LV: un module de batterie externe permettant de stocker de l'énergie pour un usage domestique. Lorsque le réseau est sous tension, elle alimente les charges domestiques tout en chargeant la batterie. Lorsque le réseau est hors tension, la batterie se décharge pour alimenter les charges domestiques.**

Le manuel d'utilisation de la batterie LFP 16 kWh/BT détaille la structure, les paramètres, les procédures de base et les méthodes d'installation, d'utilisation et de maintenance de l'appareil.

### Safety Statement

Only qualified trained professionals are allowed to install, operate, maintain the device.

Please comply with local safety regulations and operational rules when installation, operation and maintenance, or it could lead to human injury or device damage.

Mentioned attentions are only as a supplement to local safety regulations.

The seller does not undertake any responsibility for device operations or usage violating general safety requirements and safety standards.

### Déclaration de sécurité

**Seuls des professionnels qualifiés et formés sont autorisés à installer, utiliser et entretenir l'appareil.**

**Veillez respecter les réglementations de sécurité et les règles d'exploitation locales lors de l'installation, de l'utilisation et de la maintenance, sous peine de blessures corporelles ou d'endommagement de l'appareil.**

**Les précautions mentionnées ne constituent qu'un complément aux réglementations de sécurité locales.**



**Le vendeur décline toute responsabilité en cas d'utilisation ou de fonctionnement de l'appareil contraire aux exigences générales et aux normes de sécurité.**

## Sign explanation

Attention should be paid when configuring or operating LFP 16kWh/ LV products, which follows below format to explain.

## Explication des panneaux

Une attention particulière doit être portée lors de la configuration ou de l'utilisation des produits LFP16kWh/BT, qui suivent le format ci-dessous pour les expliquer.

 Danger	This instruction indicates that there are dangers during the operation process. Failure to comply with such warning information will directly lead to serious personal injury or death accidents.
 Warning	This instruction indicates that there are potential dangers during the operation process. Failure to comply with such warning information may lead to personal injury or death accidents.
 Caution	This instruction indicates that there are potential dangers during the operation process. Failure to comply with such warning information may result in equipment damage.

## CAUTION ATTENTUON

Neglecting the warnings might cause malfunction.

Le non-respect des avertissements peut entraîner un dysfonctionnement.

# 1 Introduction

## 1.1 Brief Introduction

The LFP 16kWh/LV is an externally rechargeable lithium battery pack designed to store electrical energy for household use. According to market demands, this product can provide reliable power for various household devices, and is particularly suitable for high-temperature environments, narrow spaces, as well as scenarios with high requirements for weight and service life.

The LFP 16kWh/LV lithium battery pack is equipped with an independently developed Battery Management System (BMS)

- When the power grid is normal: It supplies power to household loads and charges the battery at the same time
- When the power grid is interrupted: The battery discharges to maintain the operation of household loads

It supports parallel connection of multiple batteries to form modules, expanding capacity to meet long-term energy storage needs.

## 1.2 Product Properties

LFP 16kWh/LV energy storage product's anode materials are lithium iron phosphate, battery cells are managed effectively by BMS with better performance, the systems feature as below:

- 1.2.1 Anode materials are lithium iron phosphate ( $\text{LiFePO}_4$ ), safer with longer life span.
- 1.2.2 Carries battery management system with better performance, possesses protection function like over-discharge, over-charge, over current, abnormal temperature.
- 1.2.3 Self-management on charging and discharging, single core balancing function.
- 1.2.4 Intelligent design configures integrated inspection module, with 3 remote functions (remote-measuring, remote-communicating and remote-controlling).
- 1.2.5 Flexible configurations allow parallel of multi battery for longer stand by time.
- 1.2.6 Self-ventilation with lower system noise.
- 1.2.7 Less battery self-discharge, then recharging period can be up to 10 months during the storage.
- 1.2.8 No memory effect: The battery can be charged and discharged shallowly without the risk of memory effect.

### 1.3 Product identity definition

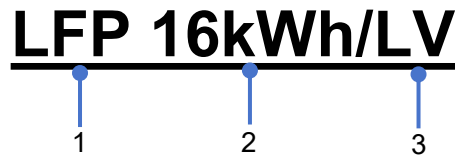

No.	Definition	Description
1	Battery cell type	LFP: lithium iron phosphate (LiFePO4)
2	Battery capacity	16kWh: Indicate that the battery nominal capacity is 16kWh
3	Voltage type	LV: The nominal DC voltage of this product is 51.2V, which is a typical low-voltage household energy storage

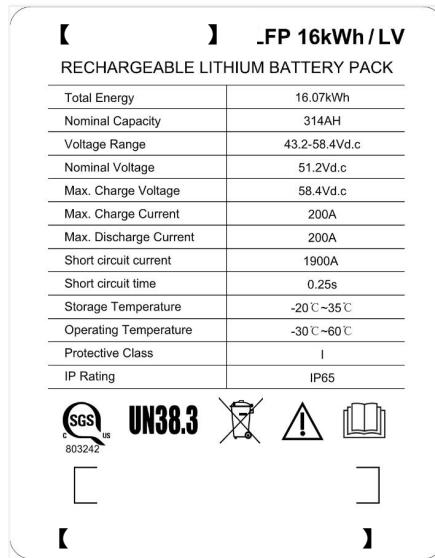

Figure 1-1 Battery Module Label

Table 1-1 Symbol Definition

Symbol	Description
	UL certification body
<b>UN38.3</b>	UN38.3 mark of conformity
	Read the user manual before using
	Do not dispose of the scrapped batteries with household waste; they must be recycled by professional personnel or institutes
	Be careful with your actions and be aware of the dangers

## 2 Product specifications

### 2.1 System Performance Parameter

Table 2-1 LFP 16KWh/LV Device Model

Product Series	Specification Model	Nominal Voltage	Nominal Capacity	Dimension	Weight	Protection level
LFP	16kWh/LV	51.2V	314Ah	530×900×245mm	120kg	IP65

Table 2-2 LFP 16KWh/LV performance parameter

Module Type	LFP 16kWh/LV
Total Energy	16kWh
Usable Capacity(90%DOD)	14.4KWh
Nominal Dis-/Charge Power	10kW
Peak Power(Only Discharge)	11.6KW for 3 seconds
Constant Current(Only Discharge)	200A
Voltage Range	43.2-58.4Vd.c
Nominal Voltage	51.2Vd.c
Nominal Current	200A
Max Charge Voltage	58.4Vd.c
Max Charge Current	200A
Max Discharge Current	200A
Safety	UN38.3、UL954000 UL9540A、LV9540、SGS UL 1973

## 2.2 Interface Definition

This section elaborates on interface functions of the front panel of the device.

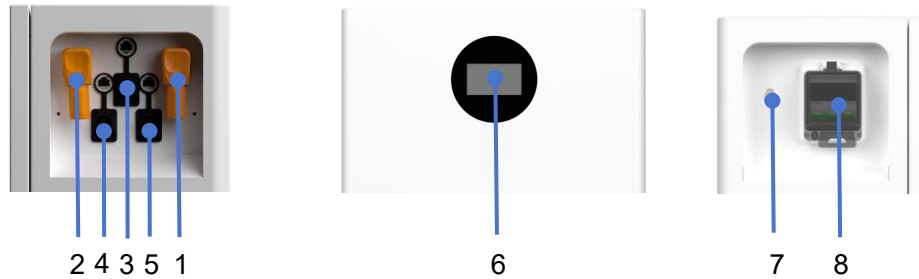

Figure 2-1 Battery Module Interface

Table 2-3 Interface Definition

NO	Item	Definition
1	Negative socket	The battery DC output negative pole, which is connected to the negative pole of the inverter via a cable
2	Positive socket	The battery DC output Positive electrode, which is connected to the Positive pole of the inverter via a cable
3	CAN	CAN communication interface is used for communication between battery and inverter
4	RS485 A	The RS485 communication interface is used for parallel communication between batteries
5	RS485 B	The RS485 communication interface is used for parallel communication between batteries
6	Display screen	Display the battery operating status.
7	Reset switch	When the switch is pressed, the battery system will start. When the battery is not in use (such as during storage, transportation, etc.), it needs to be turned off via the switch button. In addition, when the device has no external load power supply, the battery system will automatically enter the sleep state
8	Main switch	Open or cut off the main circuit, and ensure transportation safety after disconnection

## **2.3 Battery Management System(BMS)**

### **2.3.1 Voltage Protection**

#### 2.3.1.1 Low-Voltage Discharge Protection

When the voltage of any battery cell is lower than the rated protection value, or the total voltage drops below 40V during discharge, the over-discharge protection will be triggered. The battery system will sound a buzzer alarm and stop supplying power to the outside. The protection function will automatically be released after the voltage of each battery cell returns to the rated value and the total voltage rises above 43.2V.

#### 2.3.1.2 Overvoltage Protection During Charging

During charging, when the total voltage of the battery pack exceeds 57.6V or the voltage of any single battery cell reaches the protection threshold, the system will stop charging. When the total voltage drops below 56.6V, the system will automatically resume charging. When the voltage drops to 8V and the battery voltage falls below the rated protection value, the protection function will be released.

### **2.3.2 Current Protection**

#### 2.3.2.1 Overcurrent Protection During Charging

When the charging current exceeds the protection value, the battery buzzer will alarm and stop charging. The protection will be released after a rated delay of 1 minute by the system.

#### 2.3.2.2 Overcurrent Protection During Discharging

When the discharge current exceeds the protection value, the battery buzzer will alarm and the system will stop discharging. The protection will be released after a 1-minute delay by the system.

### **2.3.3 Temperature Protection**

#### 2.3.3.1 Under temperature/Overtemperature Protection During Charging:

When the battery temperature exceeds the range of 0°C to +60°C during charging, the temperature protection will be activated, and the device will stop charging. The protection will be released when the temperature returns to the rated recovery range.

#### 2.3.3.2 Undervoltage/Overvoltage Protection During Discharging:

When the battery temperature exceeds the range of -30°C to +60°C during discharging, the temperature protection will be activated, and the device will stop supplying power to the outside. The protection will be released when the temperature returns to the rated range.

## 2.3.4 Other Protections

### 2.3.4.1 Short-Circuit Protection:

When the battery is started from the off state, if a short circuit occurs, the DC circuit breaker will act first. If the DC circuit breaker does not act, the Battery Management System (BMS) will activate the short-circuit protection function and cut off the external voltage output.

### 2.3.4.2 Auto-Shutdown:

When the device is connected without an external load for more than 72 hours, it will automatically enter the sleep standby state.

#### **DANGER**

Ensure ON/OFF switch is turned on before waking up the battery. Otherwise it will affect the auto test process and cause danger.

DO NOT switch off the ON/OFF switch during normal operation, only in emergencies. Otherwise it will cause the battery current to surge.

#### **CAUTION**

If the DC breaker trips because of over-current or short circuit, you must wait for 30 minutes to switch it on again, otherwise it may cause damage to the breaker.

## 3 Installation and Configuration

### 3.1 Preparations for Installation

#### 3.1.1 Safety Requirement

This system can only be installed by personnel who have been trained in the power-supply system and have sufficient knowledge of the power system.

The safety regulations and local safety regulations listed below should always be followed during the installation.

- All circuits connected to this power system with an external voltage of less than 48V must meet the SELV requirements defined in the IEC60950 standard.
- If operating within the power system cabinet, make sure the power system is not charged. Battery devices should also be switched off.
- Distribution cable wiring should be reasonable and has the protective measures to avoid touching these cables while operating power equipment.
- The following protective items must be worn when installing the battery system:



**Insulated Gloves**



**Safety Goggles**



**Safety Shoes**

#### 3.1.2 Environmental requirements

Working temperature:  $-30^{\circ}\text{C}\sim+60^{\circ}\text{C}$

- Charging temperature range is  $0^{\circ}\text{C}\sim+60^{\circ}\text{C}$
- Discharging temperature range is  $-30^{\circ}\text{C}\sim+60^{\circ}\text{C}$

Humidity: UP to 90% ( non-condensing)

Elevation: no more than 4000m

Operating environment: Indoor or outdoor installation, sites avoid the sun and no wind, no conductive dust and corrosive gas.

And the following conditions are met:

- Installation location should be away from the sea to avoid brine and high humidity environment.
- The ground is flat and level.
- There is no flammable explosive near to the installation places.
- The optimal ambient temperature is  $+15^{\circ}\text{C}\sim+30^{\circ}\text{C}$ .
- Keep away from dust and messy zones.

### 3.1.3 Tools and data

The following tools are required to install the battery pack:

**Table 3-1 Tool instrument**

Name	
Screwdriver (flathead, Phillips, hex)	Multimeter
Wrench	Clamp meter
Diagonal pliers	Insulating tape
Needle-nose pliers	Thermometer
Crimping tool	Anti-static wrist strap
Wire stripper	Tape
Electric drill	Insulating gloves

### 3.1.4 Installation location precautions

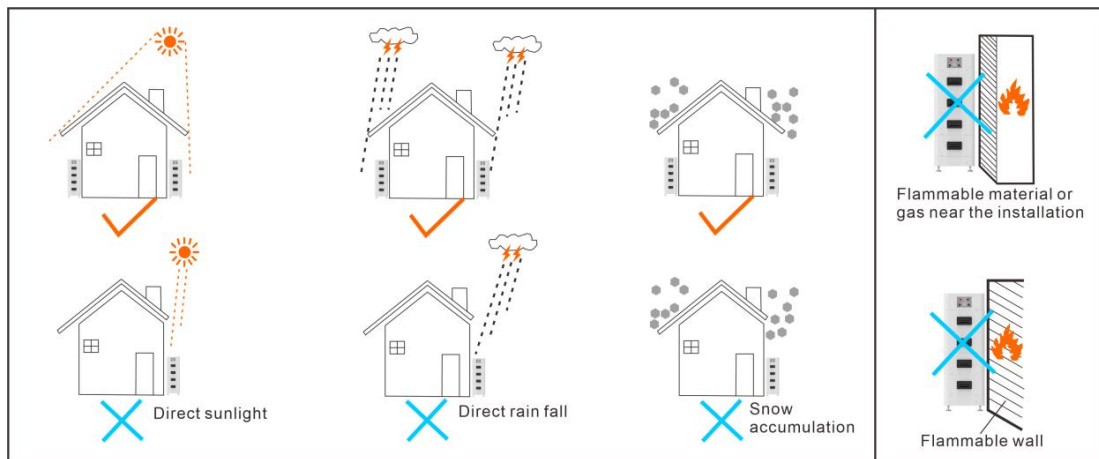

**Figure 3-1 Installation location precautions**

### **3.1.5 Technical preparation**

#### 3.1.5.1 Electrical Interface Inspection

- Devices that can be directly connected to the battery include user equipment, power supplies, or other power supply devices.
- Confirm whether the user equipment, photovoltaic equipment, or other power supply equipment is equipped with a DC backup interface, and measure whether the output voltage of this backup interface meets the voltage range requirements specified in Table 2-2.
- It is necessary to confirm that the maximum discharge current capacity, DC backup interface, and maximum discharge current of the user equipment, photovoltaic equipment, or other power supplies are all greater than the maximum charging current of the products listed in Table 2-2.
- If the maximum discharge capacity of the DC interface of the user equipment is lower than the product value of the maximum charging current specified in Table 2-2, the user interface must be equipped with a DC current limiting function to ensure the normal operation of the user equipment.

#### 3.1.5.2 Safety Inspection

- Fire-fighting equipment, such as portable dry powder fire extinguishers, should be equipped near the equipment.
- An automatic fire extinguishing system should be equipped when necessary.
- It is forbidden to place flammable, explosive, and other dangerous items next to the battery.

#### 3.1.5.3 Check list Inspection

- After the equipment arrives at the installation site, loading and unloading operations should be carried out in accordance with specifications to prevent the equipment from being exposed to sunlight and rain.
- Before unpacking, the total number of packages should be marked according to the shipping list attached to each package, and the packaging boxes should be checked for integrity.
- During the unpacking process, careful operation is required to protect the surface coating of the items.
- After unpacking, professional installers must carefully read the technical documents, check the checklist, refer to the configuration table and packing list, and confirm that all items are complete and intact. If damage to the internal packaging is found, a detailed inspection must be carried out and records must be made.

**Table 3-2 Packing list**

		
<b>Battery ×1</b>	<b>User manual ×1</b>	<b>Communication cable</b>
		
<b>Protective cover ×1</b>	<b>M6×1</b>	<b>M4×2</b>
		
<b>Power cable ×2</b>	<b>ground wire×1</b>	

### 3.1.6 Engineering Coordination

The following matters should be noted before construction:

- Power line specifications.
  - The power line specifications should meet the maximum discharge current requirements of each product.
- Installation space and load-bearing capacity.
  - Ensure that there is sufficient space for battery installation.
- Wiring layout.
  - Ensure that the layout of power lines and grounding lines is reasonable, and that short circuits, water immersion, and corrosion are not likely to occur.

### 3.2 Equipment installation

The distance between the battery and the wall, as well as the spacing on both sides of the battery, must be greater than 400 mm.

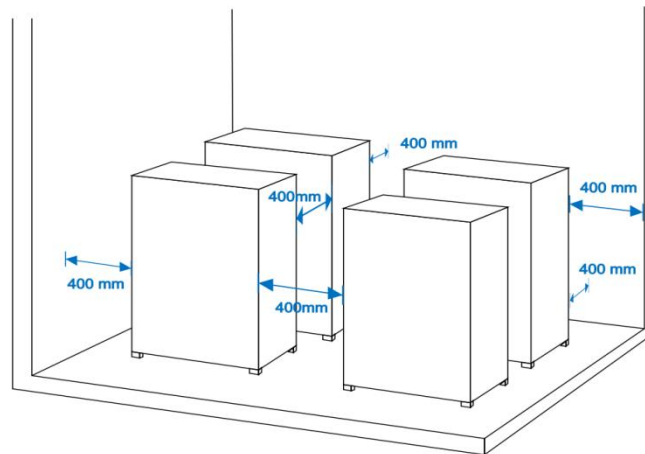

**Figure 3-2 Mounting Space Requirements**

**Table 3-3 Installation steps**

Step 1	System Outage	Ensure that the battery is in a shutdown state
Step 2	Electrical Installation	A. Connect the grounding cable B. Connect the inverter C. Communication connection
Step 3	Equipment Installation	Install protective cover

#### 3.2.1 System Outage

Ensure the battery is in a shutdown state.

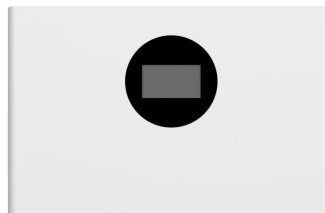

#### 3.2.2 Electrical Installation

##### 3.2.2.1 Battery Connection to Communication Cables and Power Cables

The battery output interface uses a quick-connect plug. The power cord (positive and negative) plug can be directly inserted into the battery socket, and the cross-sectional area of the power cord is 50mm<sup>2</sup>.

Before connecting the power cables, use a multimeter to measure the continuity, short-circuit condition of the cables, confirm the positive and negative poles, and accurately mark the cable labels.

The measurement methods are as follows:

- Power cord inspection: Select the buzzer mode of the multimeter to test both ends of the cable of the same color. If the buzzer sounds, it indicates that the cable is in good condition.
- Short-circuit judgment: Use the resistance range of the multimeter to detect the same end of the positive and negative poles. If the resistance shows infinity, it means the cable has no short-circuit phenomenon and can be used normally.
- After completing the visual continuity test of the power line, connect the positive and negative poles of the battery to the positive and negative poles of the opposite terminal respectively.

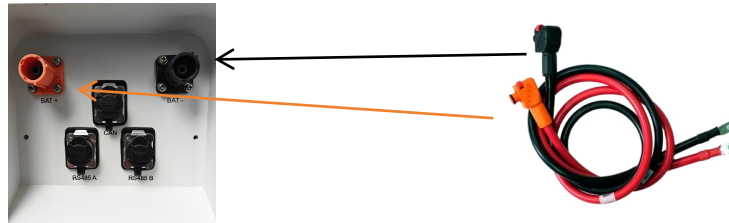

### 3.2.2.2 Connecting the Ground Cable

Fix one end of the ground cable with an M6 screw.



### 3.2.2.3 Connecting the Inverter

- When connecting the battery to the inverter, special power cords and communication cables must be used (as accessories included with the product, the standard communication cable is an ordinary network cable. The applicable inverter model is marked on the network cable label. If the inverter used by the customer is not within the scope of application of the standard communication cable, please contact us to obtain the correct PIN sequence).
- Keep the battery system in a power-off state, first connect the power cord to the input interface of the inverter, and then to the battery side interface.
- The battery output interface is a quick connector, and the power cord (positive/negative) plug can be directly inserted into the battery socket.
- The cross-sectional area of the power cord is 50mm<sup>2</sup>.

#### **⚠ CAUTION**

- If you have any questions during the installation process, please contact the dealer in a timely manner to avoid equipment damage.
- After each full charge and discharge, it needs to stand for thirty minutes.

When the system is used independently:

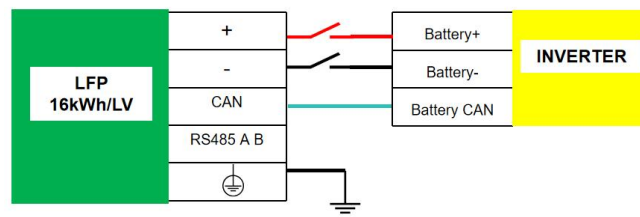
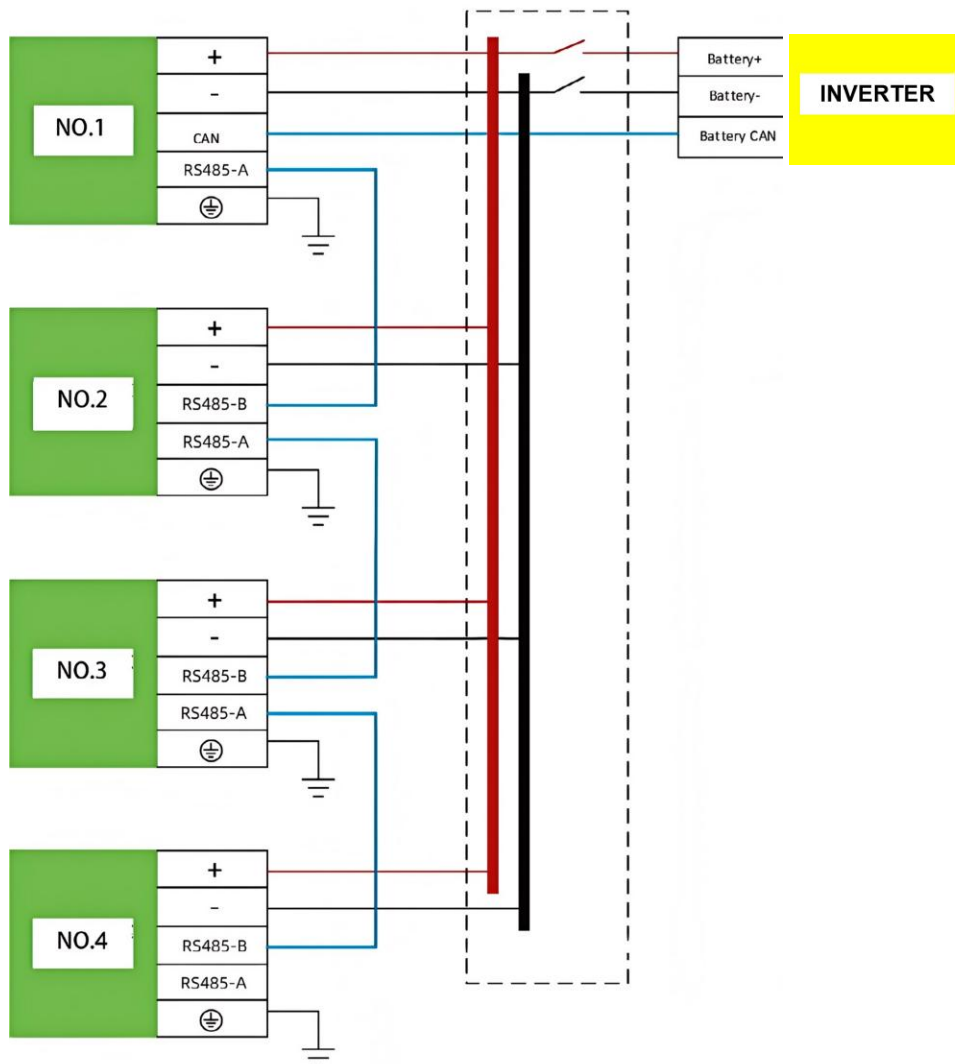

Figure 3-3 Wiring Diagram

When the system is used in parallel: A maximum of 16 clusters of battery packs can be connected in parallel.



.....NO.16

Figure 3-4 Schematic Diagram of Battery Parallel Connection

### 3.2.2.4 Communication Connection

Use an RJ45 cable to connect the CAN bus of the battery to the CAN communication interface of the inverter. The factory default setting is CAN communication mode. For cable connection, please refer to the wiring diagram in Figure 3-3.

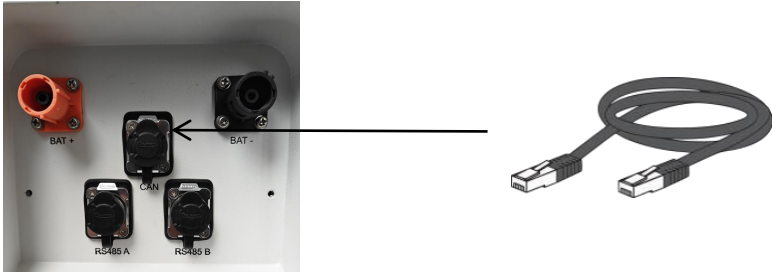

### 3.2.3 Equipment Installation

Install the protective cover: Use M4 screws to fix both sides of the protective cover.



## 4 Use, Maintenance and Troubleshooting

### 4.1 Battery System Usage and Operation Instructions

After completing the electrical installation, follow these steps to start the battery.

#### 4.1.1 Press the switch, and the screen will light up, Close the circuit breaker

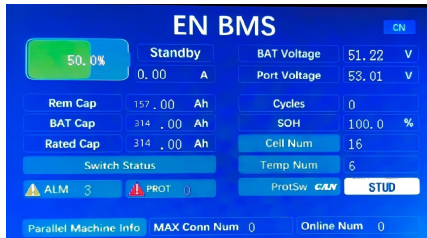

#### 4.1.2 If the battery is not connected to the inverter, the screen will display OA

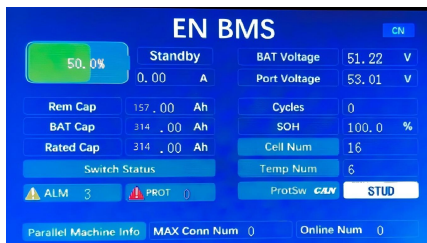

#### 4.1.3 If the battery is connected to the inverter, the screen will display the current



#### 4.1.4 Turn on the inverter

After confirming that the battery output voltage and polarity are correct, turn on the inverter. Check whether the indicator lights for the connection between the inverter and the battery (communication indicator light and battery access status indicator light) are normal. If the indicator lights are normal, it indicates that the connection between the battery and the inverter is completed. If the indicator lights are abnormal, please check the cause or contact the local dealer with the inverter manual.

## 4.2 Display screen operation Instructions

### 4.2.1 Main Interface

4.2.1.1 After the device is powered on and activated, the battery management interface will be displayed, as shown in the following figure:



4.2.1.2 Click **CN** to switch to Chinese, click **EN** to switch to English

### 4.2.2 Protocol switching page

4.2.2.1 Click the main page **ProtSw CAN STUD**

4.2.2.2 Click **ProtSw** to enter the protocol switching function, as shown in the following figure:

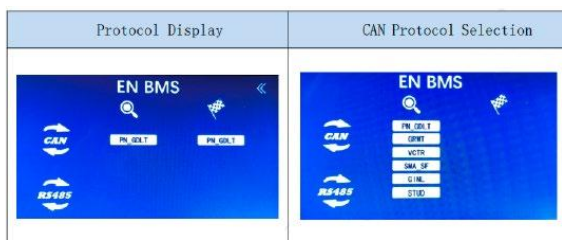

4.2.2.3 Select the corresponding CAN protocol to automatically return to the previous interface.

### 4.2.3 Battery Status Interface

Tap **告警 3** / **ALM 3** / **保护 0** / **PROT 0** on the main page to enter the alarm and protection details page, as shown in the following figure:



## 4.3 Alarm Description and Processing

### 4.3.1 Main Alarm and Protection

After starting the battery, the following alarms and protections may appear on the lithium battery screen:

**Table 4-1 Main Alarms and Protections**

Alarm	
Total voltage high voltage alarm	Charging high temperature alarm
Charging low temperature alarm	Discharging high temperature alarm
Discharging low temperature alarm	Ambient high temperature alarm
Ambient low temperature alarm	Power supply high temperature alarm
Charging overcurrent alarm	Discharging overcurrent alarm
Remaining capacity alarm	Battery low voltage charging prohibited
Current calibration not completed	Zero calibration not completed
Calendar not synchronized	
Protection	
Temperature sensing fault	Key switch fault
Battery voltage difference fault	Single cell high voltage alarm
Monitoring overvoltage protection	Total overvoltage protection
Total undervoltage protection	Charging overheating alarm
Charging overtemperature protection	Discharging overheating protection
Discharging overtemperature protection	Ambient overheating protection
Ambient overtemperature protection	Power supply overheating protection
Battery low-temperature heating	Secondary trip protection
Transient overcurrent protection	Output short-circuit protection
Transient overcurrent lockout	Transient overcurrent lockout
Charging high voltage protection	Standby capacity protection
Battery voltage difference fault	Output connection fault

## 4.4 Analysis and Treatment of Common Faults

Alarms that do not affect system output and countermeasures:

If the battery has issues such as overvoltage protection, undervoltage protection, overcurrent protection, overheating protection, short-circuit protection, and battery cell balancing protection, please refer to Table 4-2 for troubleshooting.

**Table 4-2 Problem Analysis and Resolution**



Problem	Cause	Solution measures
Over voltage Protection	The battery voltage exceeds the preset maximum safe voltage.	<p>Check if the charger is working properly and if there is any overcharging.</p> <p>Ensure that the charging voltage matches the battery's rated voltage.</p> <p>Stop charging,check if there is any fault with the battery or BMS(Battery Management System),and replace the battery if necessary.</p>
Under voltage Protection	The battery voltage is below the preset minimum safe voltage.	<p>Check if the charger is working properly and if there is any over charging.</p> <p>Ensure that the charging voltage matches the battery's rated voltage.</p> <p>Stop charging,check if there is any fault with the battery or BMS(Battery Management System),and replace the battery if necessary.</p>
Over current Protection	The battery output current exceeds the preset safe current limit.	<p>Ensure that the load device does not exceed the battery's rated output capacity.</p> <p>Check the battery connections and device interfaces for any short circuit or poor contact.</p> <p>Stop using the battery,recheck the connections between the battery and the device,and fix any issues.</p>
Over temperature Protection	The battery or its management system temperature is too high	<p>Immediately stop charging or discharging, and ensure the battery is placed in a cool environment. Make sure there are no external heat sources affecting the battery.</p> <p>Check the battery's heat dissipation. If the temperature remains excessively high, inspect the battery for potential damage, as replacement may be necessary.</p>
Short Circuit Protection	The battery experiences a short circuit,causing excessive current.	<p>Disconnect the battery from the device to prevent further damage.</p> <p>Check the battery and circuit wiring to ensure there is no short circuit.</p> <p>Replace damaged components in a timely manner.</p>

<p>Battery balancing protection</p>	<p>There is a large voltage difference between the individual batteries in the battery pack.</p>	<ul style="list-style-type: none"> <li>· This protection is usually automatically adjusted by the BMS and does not require manual intervention.</li> <li>· If cell balancing protection occurs frequently, it may indicate that some cells in the battery pack are aging faster. Check the health of individual cells or consider replacing them.</li> </ul>
-------------------------------------	--	--

<p> <b>CAUTION</b></p>
<p>Regular maintenance: Periodically check battery health and charging status to ensure the device is not damaged due to over-discharging or overcharging.</p> <p>Use certified equipment: Always use original or certified chargers and accessories to avoid battery damage caused by unstable voltage or overload.</p> <p>Environmental temperature management: Avoid using the battery in extremely high or low-temperature environments, as extreme temperatures will affect battery performance and lifespan.</p>

# 5 Bluetooth Application Connection Guide

## 5.1 Android and iOS Software download and Installation

<p>Android system</p>	<p>Download and install from the webpage  <a href="https://www.pgyer.com/1a8ce42e6c1a9f2d37dcaa6a790e40c2">https://www.pgyer.com/1a8ce42e6c1a9f2d37dcaa6a790e40c2</a>            Open the page using WeChat or a browser to scan the QR code.</p> <p>QR code</p>  <p>After downloading the APK file, click "Install".</p> <p>Latest version V1.0.17</p>
<p>iOS system</p>	<p>Search interface</p> <p>Search for "EN BMS" in the Apple Store (Note the space in the middle).</p> 

## 5.2 User Login

5.2.1. Click the application icon to open the application, and click "Switch to English" to directly switch to the English interface.

5.2.2 Enter the username and password.

default username: admin      default password: 111111

5.2.3 Click the "Login" button.



Figure 5-1 Login Interface

### 5.3 Device Connection

5.3.1 After the user logs in, the "Devices" interface will display the name of the searched device.

- Standalone mode: When all dial addresses are 0, the system displays BP00
- Parallel connection: To avoid incorrect connection by the user, only the host address BP00 is displayed; the parallel switching operation can be enabled on the main page
- The status bar 6 will be displayed after entering the application system

5.3.2 Click "Device BP00" to connect the mobile phone to the battery Bluetooth module.

In some cases, as the on-site signal may be blocked and the Bluetooth signal is unstable, please click "Research Devices" to refresh the "Devices" list.

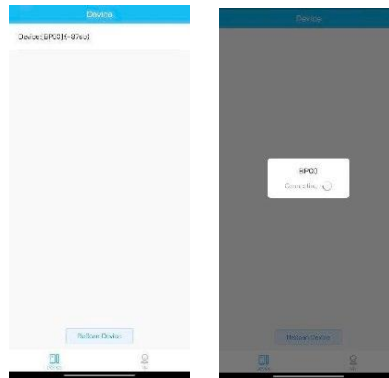

Figure 5-2 Connection Device Interface

### 5.4 APP Main Interface Display

5.4.1 Display the main interface, which can be used to show information about standalone units and parallel units.

5.4.2 Standalone mode can be selected: BP00 (master unit), BP01~BP15 (slave units); Status Bar 6 displays "Parallel BPxx".

5.4.3 When in parallel mode, Status Bar 6 displays "Parallel Parallel".

5.4.4 In parallel mode, Status Bars 1-4 display the summary data of parallel operations; The protocol type displayed in Status Bar 5 is the connection between the master unit BP00 and the inverter; Status Bar 6 is grayed out due to "Device Details"/"Configuration Parameters"/"Switch Settings" and cannot be displayed or configured except for the parallel status.

5.4.5 In standalone mode, Status Bars 2-5 all display the data of the selected standalone unit; Status Bar 6 displays the number of the selected standalone unit, "Device Details", "Configuration Parameters" and "Switch Settings"; Among them, "Configuration Parameters" and "Switch Settings" can be viewed and modified.

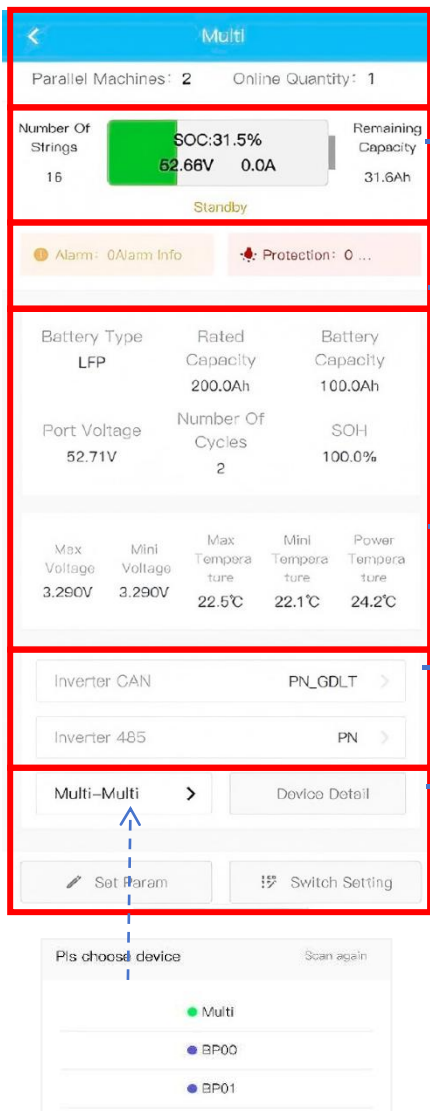

5-5

- Status Bar 1**  
Display of single-machine/parallel machine status; display of Bluetooth connection status
- Status Bar 2**  
Display of the number of battery packs, SOC, battery voltage, charge-discharge current, remaining capacity, and battery working status (charging, discharging, standby)
- Status Bar 3**  
Statistical information of alarms and protection items, click to view details. Alarm details are shown in Figure 5-3; protection details are shown in 5-4. Clicking on specific alarm/protection entries can display relevant information such as the occurrence time.
- Status Bar 4**  
Display basic battery information; display single-machine information during single-machine operation, and display parallel machine statistical information during parallel machine operation
- Status Bar 5**  
Inverter connection protocol display and settings -CAN: Supports 6 mainstream options and 10 protocols -485: Supports 5 different RS485 protocols
- Status Bar 6**  
Parallel machine/single machine display and master-slave switching, as shown in Figure 5-5. Device details: The single-machine mode (highlighted) can display detailed information of the battery pack, click to view details, as shown in Figure 5-6. Configuration parameters: The single-machine mode (highlighted) can display/configure battery pack parameters, click to view details as shown in Figure 5-7. Switch settings: The single-machine mode (highlighted) can set the battery pack switch, click to view details, as shown in Figure 5-7-1.

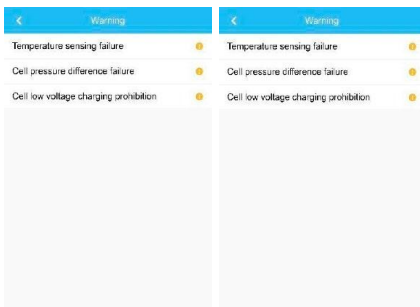

5-3

5-4

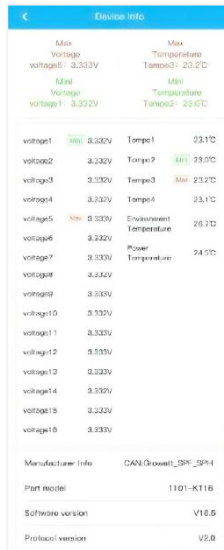

5-6

1. Display the maximum/minimum voltage of battery cells and the voltage of all individual cells
2. Display the maximum/minimum temperature and all temperature values
3. Display manufacturer information:
  - Communication method: CAN or RS485 communication
  - Protocol name: Protocol name matching the inverter
  - Component model: Customer's circuit board model
  - Software version: BMS software version
  - Protocol version: Communication protocol version between BMS and APP



5-6-1

In standalone mode (for details on switching between parallel/standalone modes, see Figure 5-5), click "Edit" (Figure 5-6-1), enter the password 111111 (Figure 5-6-2) to set the configuration parameters, and then click Save (Figure 5-6-3). After clicking "Save", the system will prompt "Confirm modification". After confirmation, the newly modified parameters will be automatically sent to the BMS board for processing.

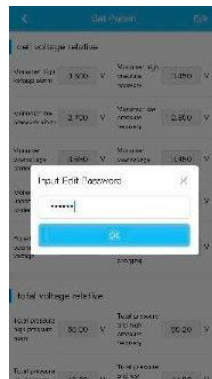

5-6-2



5-6-3



5-7-1

1. In standalone mode (for details on switching between parallel/standalone modes, please refer to Figure 5-5), click "Edit" (Figure 5-7-1), enter the password 111111 (Figure 5-7-2) to modify the function switch, and then click Save (Figure 5-7-3). 2. After clicking "Save", the system will prompt "Confirm Modification". After confirmation, the newly modified parameters will be automatically sent to the BMS control board for execution.



5-7-2



5-7-3

## 5.5 Other interface displays

1. Display "About Us" and "Change Password" and log out, as shown in Figure 5.8.1
2. Click 'About Us', as shown in Figure 5.8.2
3. Click "Change Password" to modify the login password. Click 'Done' to automatically save the changes



5-8-1

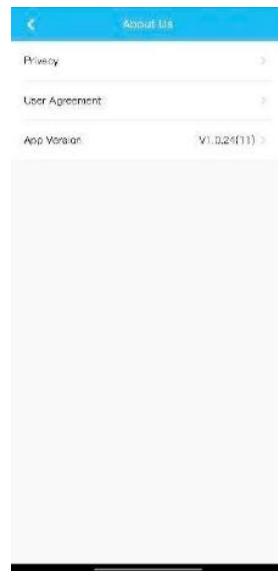

5-8-2

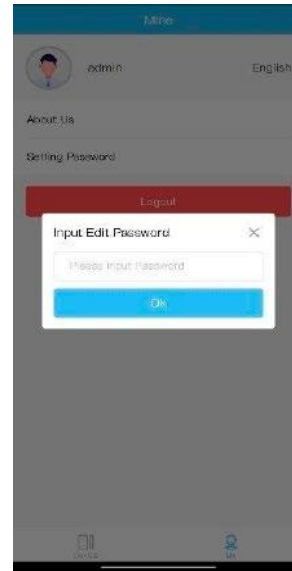

5-8-3